

FRANKLIN COUNTY ENGINEERING DEPARTMENT
VEHICULAR TRAFFIC AT THE INTERSECTION OF

AVERY ROAD AND HAYDEN RUN ROAD

NORWICH TOWNSHIP

SEPTEMBER 4 and 8, 1987

TYPE VEHICLES OBSERVED

ALL

PERIOD OF OBSERVATION

Fri. 4, 6A to 12N

Tues. 8, 12N to 6P

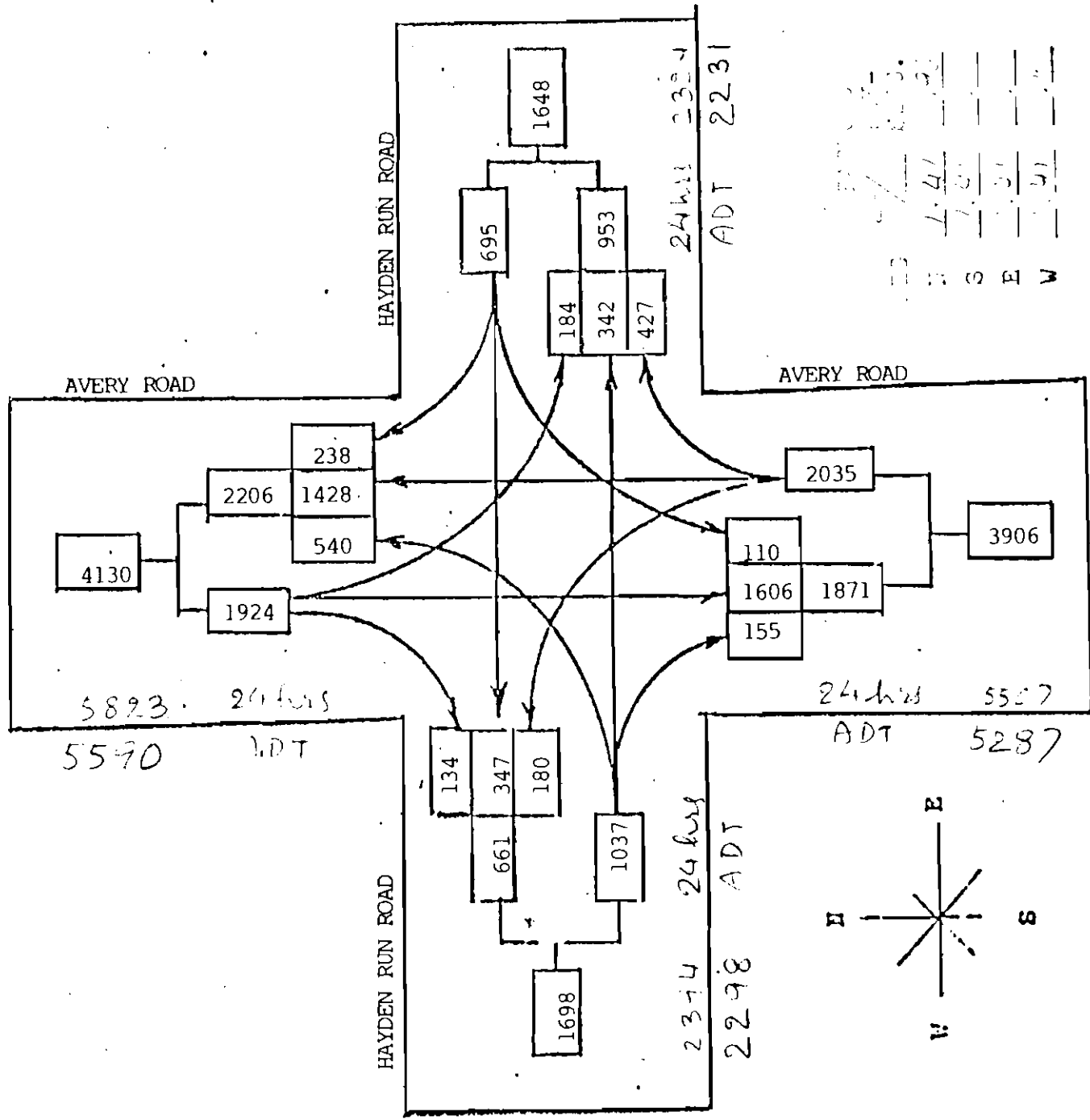

Entering Traffic Street Name	Total Flow	Number of Hours	Number	Percent	Post-Hour Flow	Time- 4:45 to 5:45PM	Number	Percent
AVERY ROAD	5691	12	3959	70%	941	4:45 to 5:45PM	711	76%
HAYDEN RUN ROAD	5691	12	1732	30%	941	4:45 to 5:45PM	230	24%
	5691	12	5691	100%	941	4:45 to 5:45PM	941	100%

Trucks are 11% of total traffic. Summary Sheet Bill Alexander

TURNING MOVEMENT COUNT RECORD SHEET

Municipality NORWICH TWP. Recorders MARK HAYMAN Date 9-08-87 Day Tues. Weather p/cldy Agency COUNTY Peak Hour NB 329 EB 54
 Prk. Restr's SB 382 WB 176
 Location AVERY ROAD AND HAYDEN RUN ROAD Time Period 12N to 6P 24/ Factor _____ Approach Width _____ NB _____ SB _____ EB _____ WB _____

HOURS		NB (S - LEG) on <u>AVERY ROAD</u>								EB (W - LEG) on <u>HAYDEN RUN RD</u>								WB (E - LEG) on <u>HAYDEN RUN RD</u>								SB (N - LEG) on <u>AVERY RD</u>								Grand Total For Intersection		
		L		S		R		Approach Total		L		S		R		Approach Total		L		S		R		Approach Total		L		S		R		Approach Total				
From	To	Pass	Com	Pass	Com	Pass	Com	Pass	Com	Pass	Com	Pass	Com	Pass	Com	Pass	Com	Pass	Com	Pass	Com	Pass	Com	Pass	Com	Pass	Com	Pass	Com	Pass	Com	Pass	Com			
12	12:30	4	1	42	4	7	6	53	11	4	1	12	0	4	4	20	5	24	6	8	0	6	2	38	8	4	4	42	14	6	0	52	18	163	42	
12:30	1	12	1	66	7	15	6	93	14	3	1	6	1	10	0	19	2	14	4	6	2	5	1	25	7	3	0	52	8	3	1	58	9	195	32	
1	1:30	6	0	41	6	13	4	60	10	3	2	11	1	8	1	22	4	15	2	8	2	5	1	28	5	2	1	36	5	3	0	41	6	151	25	
1:30	2	7	2	48	8	22	4	77	14	2	2	12	2	10	0	24	4	20	3	14	1	5	2	39	5	4	1	43	9	1	0	48	10	188	34	
2	2:30	3	0	48	7	5	1	56	8	3	0	3	0	4	1	10	1	16	4	7	0	7	1	30	5	7	1	59	5	4	0	70	6	166	20	
2:30	3	9	1	49	7	4	0	62	8	6	1	10	1	4	1	20	3	20	1	18	0	5	3	43	4	9	3	49	8	3	1	61	12	186	27	
3	3:30	9	1	55	7	12	2	76	10	12	1	13	1	10	1	35	3	21	3	15	0	4	1	40	4	6	1	60	12	4	0	70	13	221	30	
3:30	4	7	1	72	12	19	2	98	15	5	0	12	1	4	0	21	1	28	2	19	1	6	1	53	4	8	0	86	4	6	1	100	5	272	25	
4	4:15	7	0	52	4	13	0	72	4	2	0	6	2	4	0	12	2	18	0	4	0	5	0	27	0	3	0	54	3	4	1	61	4	172	10	
4:15	4:30	1	2	28	3	7	0	36	5	6	0	8	1	5	0	19	1	13	2	12	2	6	2	31	6	4	2	44	6	5	0	53	8	139	20	
4:30	4:45	4	0	47	4	12	0	63	4	1	0	5	1	11	2	17	3	9	1	6	2	1	0	16	3	7	1	51	8	2	0	60	9	156	19	
4:45	5:00	8	0	43	9	8	0	69	9	0	0	6	0	4	1	10	1	25	0	22	2	7	0	54	2	5	1	69	5	4	0	78	6	211	18	
5:00	5:15	7	0	51	0	16	0	74	0	0	0	6	0	2	0	8	0	19	1	7	0	3	0	29	1	14	0	85	1	7	0	106	1	217	2	
5:15	5:30	9	0	68	5	12	0	89	5	3	0	10	1	5	1	18	2	23	1	18	2	4	0	45	3	9	0	81	4	6	0	96	4	248	14	
5:30	5:45	4	1	59	3	15	1	78	5	0	0	11	0	4	0	15	0	25	0	11	1	5	0	41	1	6	0	76	3	5	1	87	4	221	10	
5:45	6:00	6	0	43	0	9	0	58	0	2	0	8	1	3	0	13	1	15	1	8	1	6	0	29	2	8	0	48	1	7	0	63	1	163	4	
8 HOUR P.M. TOTAL		103	10	822	86	185	26	1114	122	52	8	139	13	92	12	283	33	305	31	183	16	80	14	568	61	99	15	935	96	70	5	1104	116	3069	332	
12 HOUR TOTAL		159	21	1276	152	376	51	1811	224	98	12	306	41	214	24	618	77	485	55	303	39	129	26	917	120	153	31	1437	169	110	24	1700	224	5046	645	
ADJ 24 HOUR TOTAL																																				
ADJUSTED (ADT)																																				

TYPE OF TRAFFIC CONTROL :

(CHECK BOX, CIRCLE APPR DIRECTION)

None (NB, SB, EB, WB)

YIELD (NB, SB, EB, WB)

STOP (NB, SB, EB, WB)

FIXED-TIME SIGNAL

ACTUATED SIGNAL

SPECIAL LEFT TURN LANES (NB, SB, EB, WB)

COMMENTS :

FORM TM-28
FRANKLIN CO ENGR DEPT.
TRAFFIC DEPARTMENT
REV. 4/20/81 vnp

TURNING MOVEMENT COUNT RECORD SHEET

Municipality NORWICH TWP Recorders MARK HAYMAN Date 9-4-87 Day Fri. Weather p/cldy Agency COUNTY Peak Hour NB EB
 Location AVERY ROAD AND HAYDEN RUN ROAD Time Period 6A to 12N 24/ Factor Approach Width NB SB EB WB

HOURS		NB (S - LEG) on <u>Avery Road</u>								EB (W - LEG) on <u>Hayden Run Rd</u>								WB (E - LEG) on <u>Hayden Run Rd</u>								SB (N - LEG) on <u>Avery Rd.</u>								Grand Total For	
		L		S		R		Approach Total		L		S		R		Approach Total		L		S		R		Approach Total		L		S		R		Approach Total		Intersection	
From	To	Pass	Com	Pass	Com	Pass	Com	Pass	Com	Pass	Com	Pass	Com	Pass	Com	Pass	Com	Pass	Com	Pass	Com	Pass	Com	Pass	Com	Pass	Com	Pass	Com	Pass	Com	Pass	Com	Pass	Com
6 AM	6:30	5	0	18	2	9	1	32	3	5	0	5	1	6	0	16	1	10	1	8	2	2	1	20	4	3	1	18	1	2	1	23	3	91	11
6:30	7	3	2	16	1	11	1	30	4	4	0	7	3	10	0	21	3	6	0	12	4	4	0	22	4	5	2	29	2	5	1	39	5	112	16
7	7:30	4	0	28	2	16	1	48	3	6	1	15	4	8	1	29	6	3	1	11	2	3	1	17	4	4	2	27	3	4	3	35	8	129	21
7:30	8	3	1	36	5	15	2	54	8	5	1	18	3	13	2	36	6	19	3	11	3	6	1	36	7	6	1	32	4	5	3	43	8	169	29
8	8:30	5	3	47	8	16	3	68	14	4	0	23	5	15	2	42	7	21	0	12	5	8	3	41	8	10	1	45	5	7	5	62	11	213	40
8:30	9	4	0	40	10	14	4	58	14	5	1	26	4	14	1	45	6	18	1	10	2	4	2	32	5	8	2	46	6	6	4	60	12	195	37
9	9:30	4	1	46	10	17	3	67	14	1	1	18	2	8	4	27	7	16	1	10	0	4	0	30	1	3	0	51	4	2	0	56	4	180	26
9:30	10	4	0	35	6	12	6	51	12	1	0	9	2	4	1	14	3	5	4	4	1	3	2	12	7	2	0	35	8	0	0	37	8	114	30
10	10:30	6	1	37	5	16	2	59	8	4	0	13	0	11	0	28	0	8	5	5	0	5	0	18	5	3	1	46	9	2	0	51	10	156	23
10:30	11	7	1	49	9	22	2	78	12	6	0	5	3	10	0	21	3	27	4	11	0	4	1	42	5	2	3	64	7	3	0	69	10	210	30
11	11:30	7	2	48	5	15	0	70	7	1	0	18	1	12	1	31	2	17	2	14	2	4	1	35	5	6	1	41	11	2	0	49	12	185	26
11:30	12	4	0	54	3	24	0	82	3	4	0	10	0	11	0	25	0	30	2	12	2	2	0	44	4	2	2	68	13	2	2	72	17	223	24
6 HOUR TOTAL		56	11	454	66	187	25	697	102	46	4	167	28	122	12	335	44	180	24	120	23	49	12	349	59	54	16	502	73	40	19	596	108	1977	313

TYPE OF TRAFFIC CONTROL : NONE (NB, SB, EB, WB) STOP (NB, SB, EB, WB) ACTUATED SIGNAL
 YIELD (NB, SB, EB, WB) FIXED-TIME SIGNAL SPECIAL LEFT TURN LANES (NB, SB, EB, WB)

FORM TM-28
FRANKLIN CO. ENGR. DEPT
TRAFFIC DEPARTMENT
REV. 4/20/86 wnp

COMMENTS :