

**Cummins Consulting Services**  
**4661 Marlberry Place, Lexington, KY 40509**  
**swcummins@windstream.net 859.361.2589**  
*"simplifying Data Collection since 2004"*

File Name : Britton\_at\_Hayden\_Run\_360725\_11-01-2016

Partly Sunny - 60 Degrees  
 Schools in Session

Site Code : Site 1

Start Date : 11/1/2016

Page No : 1

Groups Printed- Cars - Buses - Trucks - Bicycles on Crosswalk - Pedestrians

Start Time	Britton Pkwy From North					Hayden Run Road From East					Britton Pkwy From South					Hayden Run Road From West					Int. Total
	Left	Thru	Right	Peds	App. Total	Left	Thru	Right	Peds	App. Total	Left	Thru	Right	Peds	App. Total	Left	Thru	Right	Peds	App. Total	
07:00 AM	29	49	8	0	86	25	73	25	0	123	13	53	34	0	100	31	90	43	0	164	473
07:15 AM	24	62	8	0	94	36	59	31	0	126	29	82	18	0	129	26	120	62	1	209	558
07:30 AM	31	94	7	0	132	34	48	22	0	104	25	84	38	0	147	27	133	57	0	217	600
07:45 AM	37	116	6	0	159	53	55	49	0	157	11	93	42	0	146	27	95	53	0	175	637
Total	121	321	29	0	471	148	235	127	0	510	78	312	132	0	522	111	438	215	1	765	2268
08:00 AM	24	71	6	0	101	45	31	41	0	117	17	79	46	0	142	16	90	32	0	138	498
08:15 AM	33	65	4	0	102	45	46	36	0	127	10	87	34	0	131	14	96	42	0	152	512
08:30 AM	24	76	6	0	106	36	38	43	0	117	25	81	23	0	129	21	102	35	0	158	510
08:45 AM	23	88	10	0	121	47	42	48	0	137	16	107	29	0	152	33	98	30	0	161	571
Total	104	300	26	0	430	173	157	168	0	498	68	354	132	0	554	84	386	139	0	609	2091
03:00 PM	30	59	18	0	107	30	81	27	0	138	20	61	36	0	117	15	65	16	2	98	460
03:15 PM	28	56	23	0	107	24	83	31	0	138	18	48	22	0	88	15	65	13	1	94	427
03:30 PM	22	58	24	0	104	39	91	30	0	160	34	63	24	0	121	13	90	13	0	116	501
03:45 PM	28	67	33	0	128	30	114	31	0	175	19	53	27	0	99	26	62	12	0	100	502
Total	108	240	98	0	446	123	369	119	0	611	91	225	109	0	425	69	282	54	3	408	1890
04:00 PM	38	94	48	0	180	38	91	36	0	165	36	59	46	0	141	26	70	16	0	112	598
04:15 PM	27	118	35	0	180	35	123	22	0	180	31	56	26	0	113	12	71	20	1	104	577
04:30 PM	48	182	51	0	281	30	126	29	0	185	35	80	57	0	172	10	78	17	0	105	743
04:45 PM	44	158	67	0	269	24	116	39	0	179	37	98	47	0	182	11	81	17	2	111	741
Total	157	552	201	0	910	127	456	126	0	709	139	293	176	0	608	59	300	70	3	432	2659
05:00 PM	71	194	56	0	321	30	109	31	0	170	42	90	58	0	190	11	76	17	0	104	785
05:15 PM	73	182	63	0	318	48	109	38	0	195	38	106	57	0	201	12	78	32	1	123	837
05:30 PM	62	193	51	0	306	47	91	48	0	186	27	85	50	4	166	16	83	33	1	133	791
05:45 PM	49	156	47	0	252	52	86	31	0	169	29	78	33	0	140	18	80	32	0	130	691
Total	255	725	217	0	1197	177	395	148	0	720	136	359	198	4	697	57	317	114	2	490	3104
Grand Total	745	2138	571	0	3454	748	1612	688	0	3048	512	1543	747	4	2806	380	1723	592	9	2704	12012
Apprch %	21.6	61.9	16.5	0		24.5	52.9	22.6	0		18.2	55	26.6	0.1		14.1	63.7	21.9	0.3		
Total %	6.2	17.8	4.8	0	28.8	6.2	13.4	5.7	0	25.4	4.3	12.8	6.2	0	23.4	3.2	14.3	4.9	0.1	22.5	
Cars	729	2116	563	0	3408	733	1580	675	0	2988	498	1523	730	0	2751	376	1701	576	0	2653	11800
% Cars	97.9	99	98.6	0	98.7	98	98	98.1	0	98	97.3	98.7	97.7	0	98	98.9	98.7	97.3	0	98.1	98.2
Buses	8	7	6	0	21	6	15	7	0	28	2	4	9	0	15	0	10	4	0	14	78
% Buses	1.1	0.3	1.1	0	0.6	0.8	0.9	1	0	0.9	0.4	0.3	1.2	0	0.5	0	0.6	0.7	0	0.5	0.6
Trucks	8	15	2	0	25	9	17	6	0	32	12	16	8	0	36	4	12	12	0	28	121
% Trucks	1.1	0.7	0.4	0	0.7	1.2	1.1	0.9	0	1	2.3	1	1.1	0	1.3	1.1	0.7	2	0	1	1
Bicycles on Crosswalk	0	0	0	0	0	0	0	0	0	0	0	0	0	2	2	0	0	0	3	3	5
% Bicycles on Crosswalk	0	0	0	0	0	0	0	0	0	0	0	0	0	50	0.1	0	0	0	33.3	0.1	0
Pedestrians	0	0	0	0	0	0	0	0	0	0	0	0	0	2	2	0	0	0	6	6	8
% Pedestrians	0	0	0	0	0	0	0	0	0	0	0	0	0	50	0.1	0	0	0	66.7	0.2	0.1

**Cummins Consulting Services**  
 4661 Marlberry Place, Lexington, KY 40509  
 swcummins@windstream.net 859.361.2589  
 "simplifying Data Collection since 2004"

File Name : Britton\_at\_Hayden\_Run\_360725\_11-01-2016  
 Site Code : Site 1  
 Start Date : 11/1/2016  
 Page No : 2

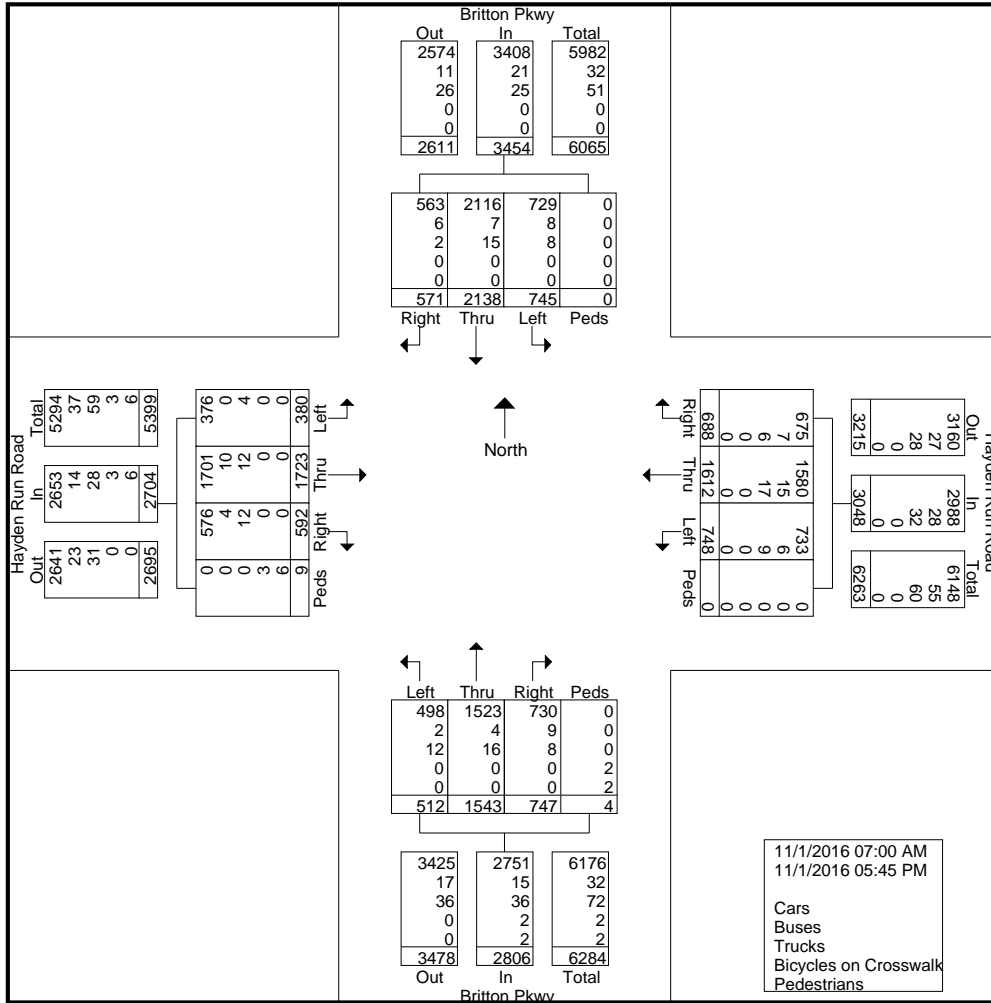

**Cummins Consulting Services**  
 4661 Marlberry Place, Lexington, KY 40509  
 swcummins@windstream.net 859.361.2589  
*"simplifying Data Collection since 2004"*

File Name : Britton\_at\_Hayden\_Run\_360725\_11-01-2016  
 Site Code : Site 1  
 Start Date : 11/1/2016  
 Page No : 3

Start Time	Britton Pkwy From North					Hayden Run Road From East					Britton Pkwy From South					Hayden Run Road From West					Int. Total
	Left	Thru	Right	Peds	App. Total	Left	Thru	Right	Peds	App. Total	Left	Thru	Right	Peds	App. Total	Left	Thru	Right	Peds	App. Total	
Peak Hour Analysis From 07:00 AM to 11:45 AM - Peak 1 of 1																					
Peak Hour for Entire Intersection Begins at 07:15 AM																					
07:15 AM	24	62	8	0	94	36	59	31	0	126	29	82	18	0	129	26	120	62	1	209	558
07:30 AM	31	94	7	0	132	34	48	22	0	104	25	84	38	0	147	27	133	57	0	217	600
07:45 AM	37	116	6	0	159	53	55	49	0	157	11	93	42	0	146	27	95	53	0	175	637
08:00 AM	24	71	6	0	101	45	31	41	0	117	17	79	46	0	142	16	90	32	0	138	498
Total Volume	116	343	27	0	486	168	193	143	0	504	82	338	144	0	564	96	438	204	1	739	2293
% App. Total	23.9	70.6	5.6	0		33.3	38.3	28.4	0		14.5	59.9	25.5	0		13	59.3	27.6	0.1		
PHF	.784	.739	.844	.000	.764	.792	.818	.730	.000	.803	.707	.909	.783	.000	.959	.889	.823	.823	.250	.851	.900

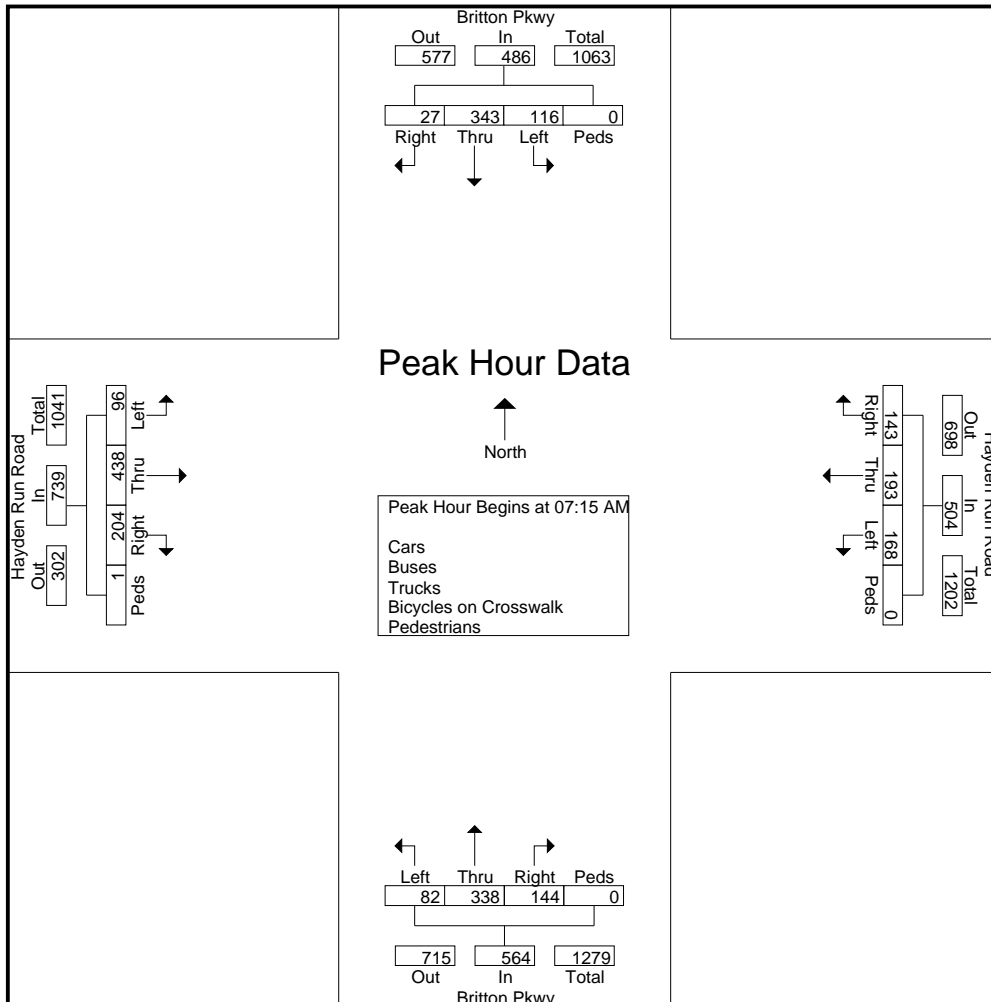

**Cummins Consulting Services**  
 4661 Marlberry Place, Lexington, KY 40509  
 swcummins@windstream.net 859.361.2589  
*"simplifying Data Collection since 2004"*

File Name : Britton\_at\_Hayden\_Run\_360725\_11-01-2016  
 Site Code : Site 1  
 Start Date : 11/1/2016  
 Page No : 4

Start Time	Britton Pkwy From North					Hayden Run Road From East					Britton Pkwy From South					Hayden Run Road From West					Int. Total
	Left	Thru	Right	Peds	App. Total	Left	Thru	Right	Peds	App. Total	Left	Thru	Right	Peds	App. Total	Left	Thru	Right	Peds	App. Total	
Peak Hour Analysis From 12:00 PM to 05:45 PM - Peak 1 of 1																					
Peak Hour for Entire Intersection Begins at 04:45 PM																					
04:45 PM	44	158	67	0	269	24	116	39	0	179	37	98	47	0	182	11	81	17	2	111	741
05:00 PM	71	194	56	0	321	30	109	31	0	170	42	90	58	0	190	11	76	17	0	104	785
05:15 PM	73	182	63	0	318	48	109	38	0	195	38	106	57	0	201	12	78	32	1	123	837
05:30 PM	62	193	51	0	306	47	91	48	0	186	27	85	50	4	166	16	83	33	1	133	791
Total Volume	250	727	237	0	1214	149	425	156	0	730	144	379	212	4	739	50	318	99	4	471	3154
% App. Total	20.6	59.9	19.5	0		20.4	58.2	21.4	0		19.5	51.3	28.7	0.5		10.6	67.5	21	0.8		
PHF	.856	.937	.884	.000	.945	.776	.916	.813	.000	.936	.857	.894	.914	.250	.919	.781	.958	.750	.500	.885	.942

